



Rewarding Learning

ADVANCED SUBSIDIARY (AS)
General Certificate of Education
2019

Centre Number

--	--	--	--	--

Candidate Number

--	--	--	--

Physics

Assessment Unit AS 3A

assessing

Practical Techniques
and Data Analysis

MV18

[SPH31]

FRIDAY 3 MAY, MORNING

Time

1 hour, plus your additional time allowance.

Instructions to Candidates

Write your Centre Number and Candidate Number in the spaces provided at the top of this page.

Answer **all** the questions in this booklet. Rough work and calculations must also be done in this booklet. Except where instructed, do **not** describe the apparatus or experimental procedures. The Teacher/Supervisor will tell you the order in which you are to answer the questions. One hour is to be spent on four short experimental tests.

After 12 minutes you must stop using the apparatus so that it can be rearranged for the next candidate.

At 14 minutes you will be instructed to move to the station for the next question.

At the end of the test a 4 minute period will be provided for you to complete your answer to any question, but you will not have access to the apparatus during this time.

Information for Candidates

The total mark for this paper is 40.

Figures in brackets printed at the end of each question indicate the marks awarded to each question or part question.

You may use an electronic calculator.

Blank Page

(Questions start overleaf)

1 Determine the energy stored in a stretched spring.

Equation 1.1 gives the relationship between the strain energy **E** stored in a stretched spring and the extension **x** of the spring when a force **F** is applied.

$$E = \frac{1}{2}Fx \quad \text{Equation 1.1}$$

(a) Use the apparatus provided to take suitable readings from which you can determine the energy stored when a mass of 200 g and a mass of 400 g is suspended from the spring.

(i) Measure the original length of the spring. [1 mark]

Original length = _____ cm

(ii) Suspend the 200 g mass from the spring. Complete the remaining columns of **Table 1.1**.

Repeat the process with the 400 g mass. [4 marks]

Table 1.1

Mass / g	Force / N	New length of spring / cm	Extension / cm
200			
400			

(iii) State the value of the uncertainty in the measured lengths of the spring. Explain the source of this uncertainty. [1 mark]

Uncertainty = _____ cm

(iv) State the uncertainty in the extension of the spring. [1 mark]

Uncertainty = _____ cm

(b) (i) Calculate the energy stored in the spring when each mass is suspended. [2 marks]

Energy stored with 200 g mass suspended
= _____ J

Energy stored with 400 g mass suspended
= _____ J

(ii) A student uses **Equation 1.1** on page 4 to predict that the energy stored is proportional to the applied force. Your results should show that this is not the case.

Explain why this prediction is not correct. [1 mark]

Blank Page

(Questions continue overleaf)

2 Determine the resistance of unknown resistors.

You have been provided with two resistor networks. Each network is made up from three resistors, two equal resistors labelled **A** and the other resistor labelled **B**. You are also provided with a power supply, voltmeter and a milliammeter.

- (a) Connect up a suitable circuit from which you can determine the resistance of each network. Take appropriate readings and record them in **Table 2.1**.

You do not need to take repeat readings in this experiment.

Calculate the resistance of each network and record the values in **Table 2.1**. [7 marks]

Table 2.1

Network			
All three resistors in series			
The two A resistors in parallel connected in series with B			

(b) Calculate the resistance of resistor **A** and resistor **B**.
[3 marks]

Resistor **A** = _____ Ω

Resistor **B** = _____ Ω

Blank Page

3 Determine the mass of an oscillating system.

You have been provided with two oscillating systems of different mass. System 1 is sitting vertically on the desk as shown in **Fig. 3.1a**. When the system is displaced slightly it will undergo oscillations.

The period of oscillation is the time taken for the system to oscillate from A to B and back to A again as shown in **Fig. 3.1b**.

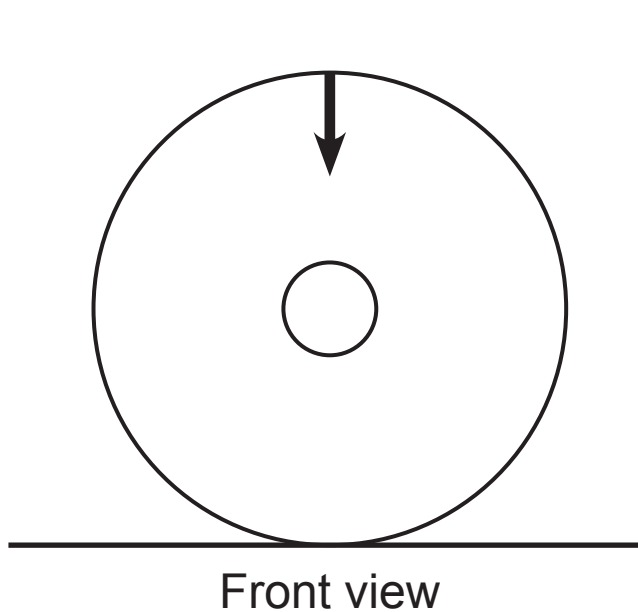

Front view

Fig. 3.1a

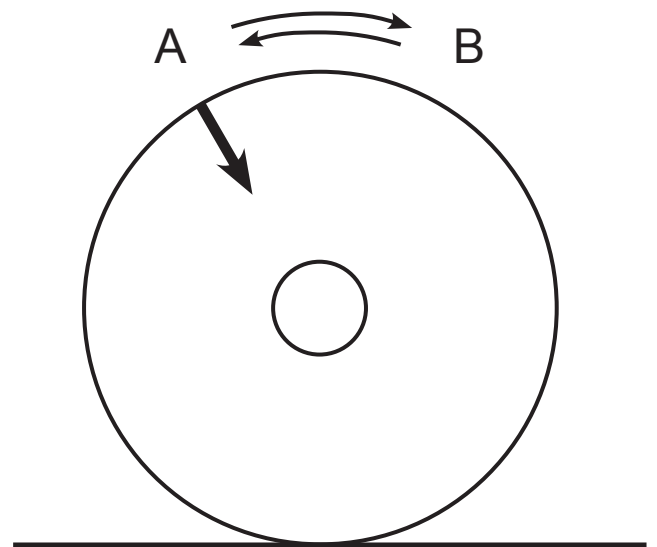

Fig. 3.1b

The mass m of each system has been recorded in **Table 3.1**.

- (a) Displace system 1 slightly by placing your finger above the arrow drawn on the system and rotate it slightly to position A as shown in **Fig. 3.1b**. Release the system to allow it to oscillate.

Take suitable readings from which you can calculate an accurate and reliable value for the period of oscillation T of the system. Record all your readings in **Table 3.1**. Repeat this procedure for system 2. [6 marks]

Table 3.1

System	m / g		Period of Oscillation T / s
1	25		
2	45		

(b) T is inversely proportional to \sqrt{m} . Use your results to obtain a value for the mass of another system that has a period of oscillation of 0.30 s. [4 marks]

$m =$ _____ g

4 Determine the refractive index.

You have been provided with a glass block and a plane mirror. Follow the instructions carefully to construct a ray diagram from which you will take measurements to calculate a value for the refractive index of the block.

(a) (i) Preparation

Referring to **Fig. 4.2** on page 17, set the face of the glass block labelled F onto the page with the long edge on the line labelled 'top edge of block' and the corner of the glass block in the position labelled.

Draw around the glass block.

Draw a line parallel to the glass block that is 5.0 cm away from the bottom edge of the glass block.

Place the mirror on this line as illustrated in **Fig. 4.1** opposite. [1 mark]

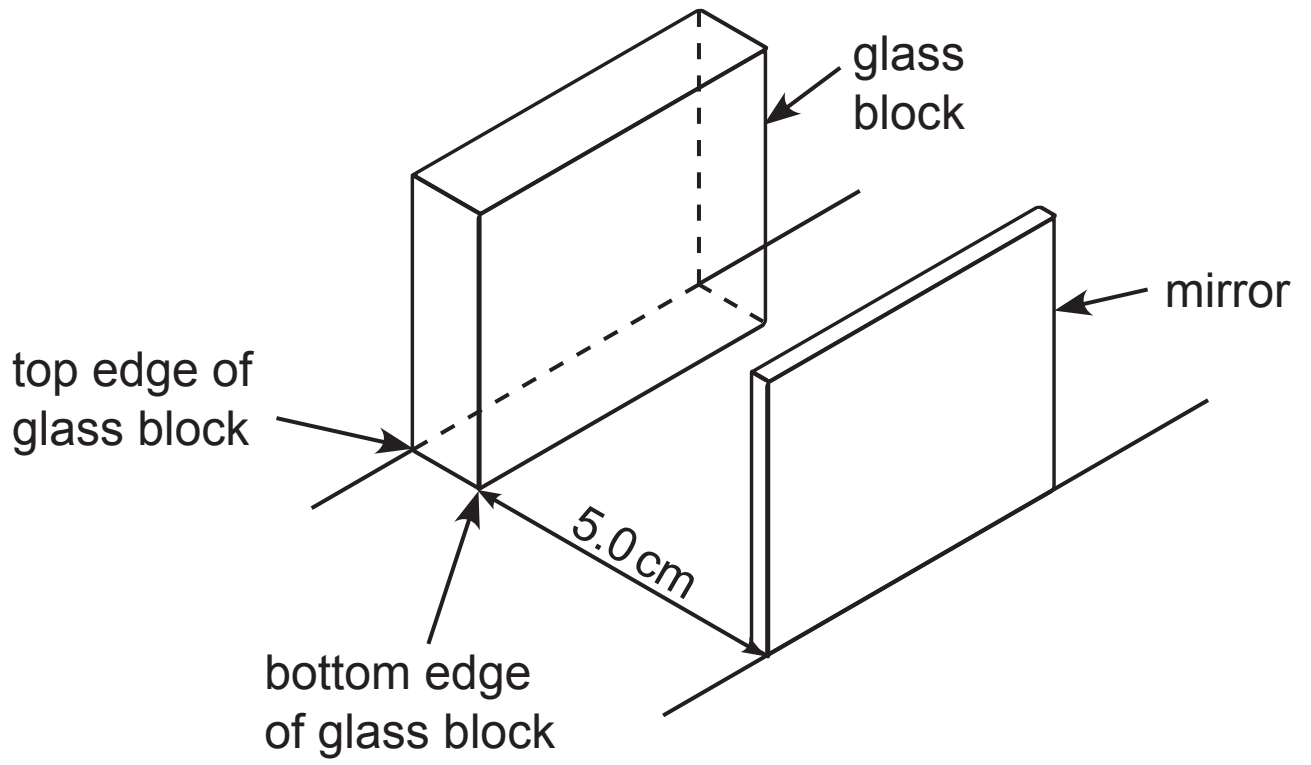

Fig. 4.1

(ii) Construction of ray diagram

Shine a ray of light along the line labelled 'incident ray' in **Fig. 4.2** opposite. Mark suitable points to allow you to draw the path of the light as it passes through the block, leaves the block, reflects from the mirror and passes through the block again, leaving the block from the same edge as it entered.

Remove the block and the mirror and draw in the complete path of the ray. [3 marks]

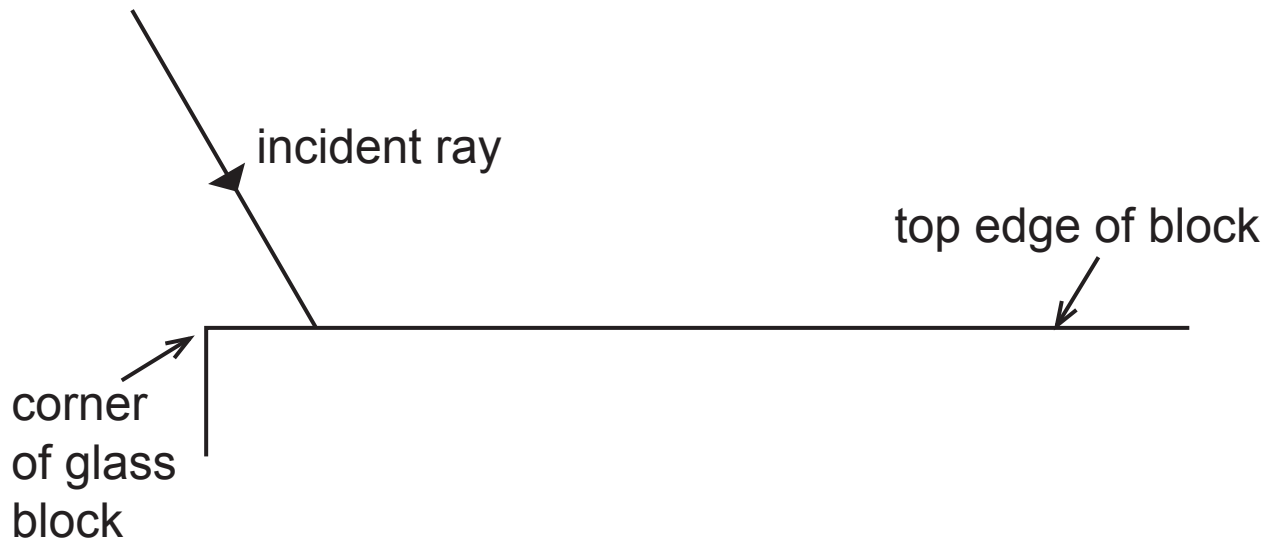

Fig. 4.2

(iii) Measurements

Measure the following: [4 marks]

The length of the path of the ray of light inside the glass block as it passes from the top edge to the bottom edge. This is X.

X = _____ cm

The length of the path of the ray of light between the glass block and the mirror. This is Y.

Y = _____ cm

The distance between the point at which the ray of light enters and leaves the block along the top edge. This is A.

A = _____ cm

The distance between the point at which the ray of light leaves and enters the block along the bottom edge. This is B.

B = _____ cm

(b) The refractive index n can be calculated using the measurements recorded in (a)(iii) using **Equation 4.1**.

$$n = \frac{BX}{Y(A-B)} \quad \text{Equation 4.1}$$

Use your measurements to calculate a value for the refractive index. [2 marks]

Refractive index = _____

This is the end of the question paper

For Examiner's use only		
Question Number	Marks	Remark
1		
2		
3		
4		
Total Marks		

Permission to reproduce all copyright material has been applied for. In some cases, efforts to contact copyright holders may have been unsuccessful and CCEA will be happy to rectify any omissions of acknowledgement in future if notified.



Rewarding Learning

**ADVANCED SUBSIDIARY (AS)
General Certificate of Education
2019**

Physics

Assessment Unit AS 3A

Practical Techniques and Data Analysis

**[SPH31]
FRIDAY 3 MAY**

APPARATUS AND MATERIALS LIST

PHYSICS UNIT 3 (AS 3A)
APPARATUS AND MATERIALS REQUIRED FOR PRACTICAL ASSESSMENT

CONFIDENTIAL

This document gives preliminary information on the apparatus and materials required for the AS Practical Assessment.

Information about the apparatus and materials required for this assessment must NOT be communicated to students. If apparatus/materials have their serial code and/or manufacturer specified then it is essential that centres use this exact apparatus/material.

On receipt of this APPARATUS AND MATERIALS LIST, centres must contact Gavin Gray, ggray@ccea.org.uk immediately if they have difficulty in sourcing the specified apparatus or materials.

Teachers will be given detailed instructions for setting up the experiment in the *Confidential Instructions for Physics (Advanced Subsidiary) Practical Test*, to which they will have confidential access from April 2019.

Teachers will have confidential access to a copy of the experimental test two working days (48 hours) before the start of the assessment.

The AS 3 Practical Techniques Assessment is a test of practical skills consisting of 4 short experimental tests (40 marks). The duration of the assessment is 1 hour.

The apparatus in the following list will allow for **one experiment** to be set up for the practical test which makes up questions 1–4. In other words, each set of apparatus (as listed on **pages 4 and 5**) will accommodate four candidates when doing the circus of experiments.

The apparatus can be used for alternative sessions according to the following schedule:

3 May 2019 Physics AS 3A (SPH31)

(Main Session) **9.15 am–10.15 am**

(First Alternative) **10.30 am–11.30 am**

(Second Alternative) **11.45 am–12.45 pm**

(Third Alternative) **1.15 pm–2.15 pm**

(Fourth Alternative) **2.30 pm–3.30 pm**

One set of apparatus for AS 3A (SPH31) will therefore be sufficient for twenty candidates on **3 May** if the Main Session and all four alternatives are used. A laboratory may contain one, two, three or more sets of apparatus. This means that four, eight, twelve or more candidates can be accommodated in the same session. **To maintain the confidentiality of details of the practical tests, candidates entered for any of the alternative sessions must be segregated within the centre so that there can be no communication with candidates who have taken an earlier test in any centre.**

IMPORTANT NOTICE

Centres are urged to order items needed for the Physics Practical Tests from the suppliers as soon as possible.

Question 1

- Extension (disposable) spring unextended length 20 mm
- 100 g mass holder × 2
- 100 g slotted mass × 4
- Half metre rule
- Retort stand, boss head and clamp
- Labels

Question 2

- 22 Ω resistor × 4
- 15 Ω resistor × 2
- Milliammeter (range 0–200 mA reading to 0.1 mA)
- Voltmeter (range 0–20V to 0.01V)
- Connecting wires with fitted plug × 5
- Crocodile clips × 2
- 4.5 V d.c. supply (batteries or power pack)
- Box or similar to conceal power supply
- Masking tape
- Labels

Question 3

- Single layer DVD or CD ROM × 4
- 10 g mass (diameter approx. 33 mm) × 2
- 20 g mass (diameter approx. 33 mm) × 2
- Stopclock
- Double sided foam sticky pads, e.g. Sellotape sticky fixers × 6
- Labels/marker suitable for writing on DVD

Question 4

- Ray box and suitable power supply
- Single slit
- Mirror and holder
- 30 cm ruler
- Rectangular glass block (NB: a block with a white face is not suitable for this experiment)
- Sticky label



Rewarding Learning

**ADVANCED SUBSIDIARY (AS)
General Certificate of Education
2019**

Physics

Assessment Unit AS 3A

Practical Techniques and Data Analysis

**[SPH31]
FRIDAY 3 MAY**

**CONFIDENTIAL
INSTRUCTIONS**

1 Confidential Instructions

These instructions will give detailed guidance on setting up and testing the apparatus and materials to be used. **Again, information contained within the Confidential Instructions must not be relayed to candidates under any circumstances.** If at this point, centres find that the testing process produces results different to those specified in the Confidential Instructions, they must contact the CCEA Science Subject Officer (ggray@ccea.org.uk) immediately.

2 Final Apparatus Testing

The practical assessment question paper will be made available to the Head of Physics **two** working days before the timetabled starting time so that teachers and technicians can carry out a final test on the experiments. If on checking the apparatus gives unexpected results, the CCEA Physics Subject Officer should be contacted immediately (ggray@ccea.org.uk). If the problem cannot be resolved, then the centre must e-mail the CCEA Physics Subject Officer stating the centre name and number, the specific nature of the problem and the range of anomalous results produced. CCEA will respond by acknowledging receipt of the e-mail. If you do not receive a response within 24 hours, please contact the CCEA Physics Subject Officer by telephone (028 90261200 Ext 2270) to confirm that CCEA has received your e-mail.

3 Practical Assessment AS 3A

The AS 3A Practical Techniques Assessment is a test of practical skills comprised of 4 short experimental tests. The duration of the assessment is 1 hour. Some of this time will be set aside for supervisors to re-set the apparatus ready for the next candidates. The assessment should be run as a circus of experiments with candidates moving to the next experiment at the designated time. The assessment should be timed as follows:

Questions	Time
Q1 (Short practical test)	12 minutes
Changeover and practical write-up	2 minutes
Q2 (Short practical test)	12 minutes
Changeover and practical write-up	2 minutes
Q3 (Short practical test)	12 minutes
Changeover and practical write-up	2 minutes
Q4 (Short practical test)	12 minutes
Changeover and practical write-up	2 minutes
End of test write-up	4 minutes

At the end of each 12 minute period, candidates must stop using the apparatus. During each 2 minute changeover period candidates may write up anything they have not completed however they will not have access to the apparatus.

At the end of the test a 4 minute period is provided for candidates to complete their answer to any question, however they will not have access to the apparatus.

4 After the Practical Assessments

When the individual exam sessions have finished, please return the AS 3A practical scripts together with the corresponding advice notes to the examinations officer (EO). We will collect these by the day after the examination. If we don't, please contact us immediately to arrange another time for collection.

Where the centre finds that a candidate may have been disadvantaged because the apparatus did not function as intended, the supervising teachers should make a report to the EO. The EO will forward the confidential report on the issue and the candidates affected to the centre support section at CCEA for special consideration. Candidates should be identified by their examination number.

IMPORTANT NOTICE

Centres are urged to order items needed for the Physics Practical Tests from the suppliers as soon as possible.

Question 1

Requirements

- Extension (disposable) spring unextended length 20 mm
- 100 g mass holder × 2
- 100 g slotted mass × 4
- Half metre rule
- Retort stand, boss head & clamp
- Labels

Preparation

Connect the boss head and clamp to the retort stand.

Before the examination

Suspend the unextended spring from the clamp.

Place one 100 g mass onto a 100 g mass hanger, label this '200g'.

Place three 100 g masses onto the other mass hanger, label this '400g'.

Set these beside the retort stand.

Set the half metre rule close to the retort stand.

Action at changeover

Return the apparatus to the original arrangement on the bench.

Question 2

Requirements

- $22\ \Omega$ resistor \times 4
- $15\ \Omega$ resistor \times 2
- Milliammeter (range 0–200 mA reading to 0.1 mA)
- Voltmeter (range 0–20V to 0.01V)
- Connecting wires with fitted plug \times 5
- Crocodile clips \times 2
- 4.5V d.c. supply (batteries or power pack)
- Box or similar to conceal power supply
- Masking tape
- Labels

Preparation

Use the masking tape to conceal the markings on all the resistors. Label the $22\ \Omega$ resistors 'A' and the $15\ \Omega$ resistors 'B'.

Connect two $22\ \Omega$ resistors and a $15\ \Omega$ resistor in series.

Connect two $22\ \Omega$ resistors in parallel with each other and put these in series with a $15\ \Omega$ resistor.

Conceal the power supply and leave the two end terminals exposed with leads attached.

Label the concealed box 'power supply'.

Set the milliammeter to the 200 mA setting and tape the dial in place so that it cannot be moved by the candidate.

Before the examination

Leave all the equipment on the desk – both resistor networks, the concealed power supply, milliammeter, voltmeter and the remaining three connecting wires and crocodile clips.

Action at changeover

Disconnect any circuit, returning the apparatus to the original arrangement.

Question 3

Requirements

- Single layer DVD or CD ROM × 4
- 10g mass (diameter approx. 33mm) × 2
- 20g mass (diameter approx. 33mm) × 2
- Stopclock
- Double sided foam sticky pads, e.g. Sellotape sticky fixers × 6
- Labels/marker suitable for writing on DVD

Preparation

Use the double sided foam sticky pads to stick one of the 10g masses to the DVD/CD as shown in **Fig 3.1**. Stick another 10g mass directly on top of the first and then a second DVD/CD on top. Label this 'System 1: $m = 25g$ '. The arrangement should sit as shown in **Fig 3.1**.

Repeat with the other 2 DVD/CDs, this time with two 20g masses stuck in between. Label this 'System 2: $m = 45g$ '.

Draw an arrow pointing vertically downwards when the DVD/CD sits on the bench as shown in **Fig 3.2**.

When displaced slightly the system should oscillate in excess of 10 oscillations. The period of oscillation of System 2 should be less than System 1.

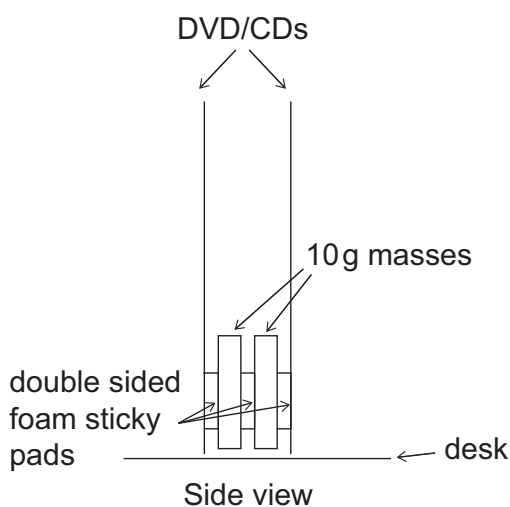

Fig. 3.1

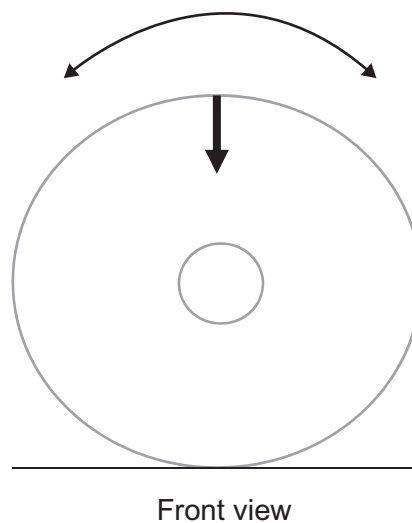

Fig. 3.2

Before the examination

Set system 1 upright on the desk. Leave the other on the desk close by with the stopclock.

Action at changeover

Return the apparatus to the original arrangement.

Question 4

Requirements

- Raybox and suitable power supply
- Single slit
- Mirror and holder
- 30 cm ruler
- Rectangular glass block (NB: A block with a white face is not suitable for this experiment)
- Sticky label

Preparation

Place a sticky label on the long narrow face of the block and label it F.

To ensure the complete path of the ray is visible, it is best to place the apparatus for Question 4 in a dimly lit area.

Before the examination

Connect the power pack to the raybox and insert the single slit into the raybox. Set all of the apparatus on the desk.

Action at changeover

Return the apparatus to the original arrangement.

